

Solar Storage Inverter

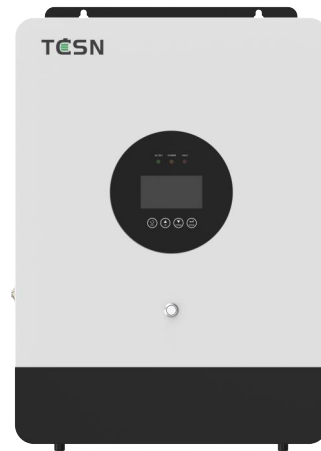

Introduce

Solar energy storage inverter features an industrial design with a modern aesthetic, easy to install and operate. It supports pure sine wave output and MPPT intelligent management for stable and reliable power supply, ideal for home energy storage, emergency power backup and household electrical appliances.



Reliable and long-lasting

Easy and quick maintenance
Design life: 15 years



Safe and worry-free

Lithium Battery Activation &
Wake-Up Protection:
OTP / OLP / OVP / OCP / SCP



Quick Installation

Industrial design with
modern aesthetic
Easy to install and operate



Scalable Capacity

It supports up to 6 units in parallel
operation.



High Efficiency

High power density, low cost
Typical switching time: 10ms



Integrated Functions

Supports RS485 / USB
WiFi wireless network (optional)

System Management Diagram

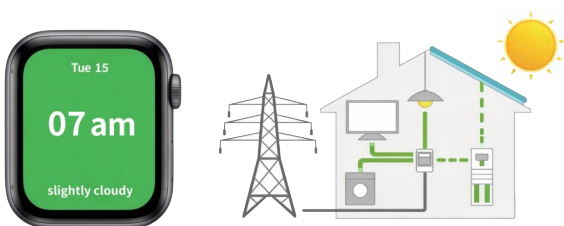
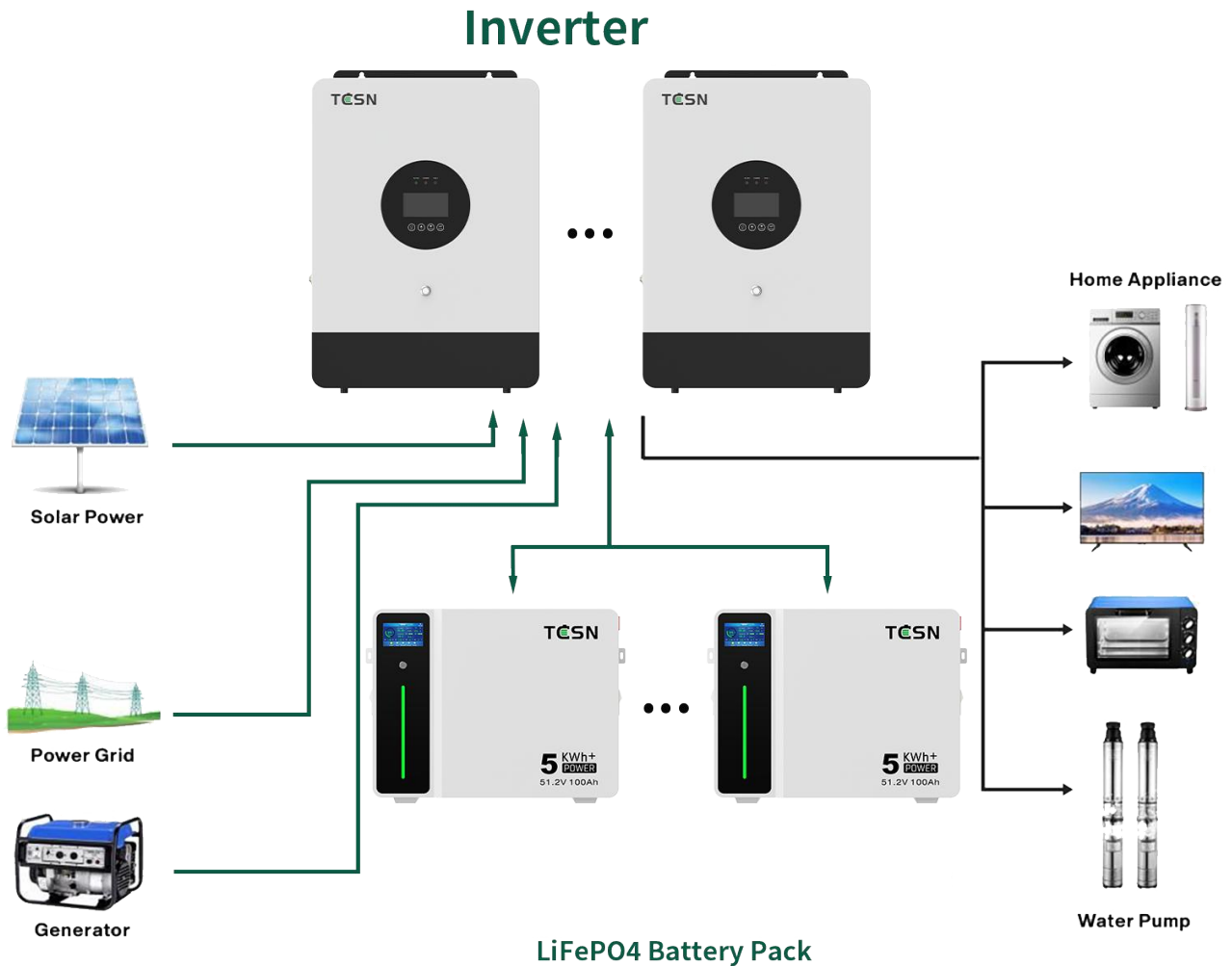

Solar energy is best used to power household appliances, with any excess energy stored in the battery.

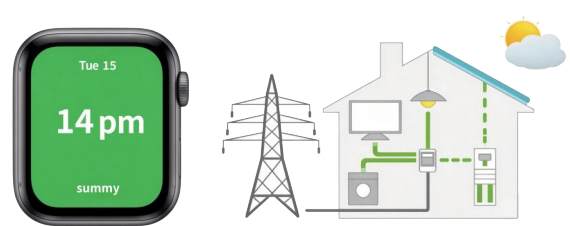

During the day, when there is insufficient light, the energy stored in the battery will be used to supplement the power supply.



At night, the energy stored in the battery powers household appliances.



When the stored energy in the battery is depleted, the public grid supplies power to household appliances.

Specifications

Model	Merak SPI B48-6K
AC Input	
Rate Input Voltage(VAC)	220/230;L+N+PE
Voltage Range(VAC)	90~280±3 (normal mode) ; 170~280±3 (UPS mode)
Frequency(Hz)	50Hz/60Hz (Auto detection)
AC Output	
Rated Capacity(kW)	6.2
Voltage Regulation	≤5%
Rate Voltage(VAC)	230,L+N+PE
Power Factor(PF)	1
Frequency	50Hz±0.3Hz/60Hz±0.3Hz
Transfer Time(ms)	10ms(Typical)
Maximum Efficiency	>94%
OverLoad Capacity	(102% < load < 125%) ±10%: report error and turn off the output after 5 minutes; (125% < load < 150%) ± 10%: report error and turn off the output after 10 seconds; Load >150% ±10%:report error and turn off the output after 5 seconds;
Permitted parallel number	No/1-6
Charger(PV/AC)	
Solar Charger Type	MPPT
Max PV input power(W)	6500
PV Voltage Accuracy	±2%
MPPT tracking range (VDC)	90~450
Maximum PV input current	27A
Max PV voltage(VDC)	500
PV charging current range	100A(Can Be Set)
Charger(AC Mode)	
Max AC Charge Current(A)	80A(Can Be Set)
Rated Charge Voltage	54.4V~55.2V
Battery	
Battery type	Lithium-ion/VRLA/Custom
Battery over Voltage Protection (VDC)	60
Battery under voltage Protection(VDC)	40
Interface	
HMI	LCD
Monitoring	WiFi(Optional)
General Data	
Ingress Protection	IP20
Operating Temperature	-10°C~50°C
Relative Humidity	20%~95%(Non-condensing)
Storage Temperature	-25°C~60°C
Net Weight(kg)	9.2
Dimensions(W*D*H)	305×416×120mm
Max.Operating Altitude	4000m(Derating above 1000m)
Noise Emission	≤60dB